

<b>IMPORTANT:</b> Read Before Using	<b>IMPORTANT :</b> Lire avant usage	<b>IMPORTANTE:</b> Leer antes de usar
--	--	--



**Operating/Safety Instructions**  
**Consignes de sécurité/d'utilisation**  
**Instrucciones de funcionamiento y seguridad**



**RH328VC**  
**RH328VCQ**



# BOSCH





Call Toll Free for  
Consumer Information  
& Service Locations

Pour obtenir des informations  
et les adresses de nos centres  
de service après-vente,  
appelez ce numéro gratuit

Llame gratis para  
obtener información  
para el consumidor y  
ubicaciones de servicio

**1-877-BOSCH99 (1-877-267-2499) www.boschtools.com**

For English Version See page 2	Version française Voir page 13	Versión en español Ver la página 24
-----------------------------------	-----------------------------------	--

<b>Safety Symbols</b>	
The definitions below describe the level of severity for each signal word. Please read the manual and pay attention to these symbols.	
	This is the safety alert symbol. It is used to alert you to potential personal injury hazards. Obey all safety messages that follow this symbol to avoid possible injury or death.
	<b>DANGER</b> indicates a hazardous situation which, if not avoided, will result in death or serious injury.
	<b>WARNING</b> indicates a hazardous situation which, if not avoided, could result in death or serious injury.
	<b>CAUTION</b> , used with the safety alert symbol, indicates a hazardous situation which, if not avoided, will result in minor or moderate injury.

### General Power Tool Safety Warnings

**WARNING** Read all safety warnings and all instructions. Failure to follow the warnings and instructions may result in electric shock, fire and/or serious injury.

#### SAVE ALL WARNINGS AND INSTRUCTIONS FOR FUTURE REFERENCE

The term "power tool" in the warnings refers to your mains-operated (corded) power tool or battery-operated (cordless) power tool.

#### Work area safety

**Keep work area clean and well lit.** Cluttered or dark areas invite accidents.

**Do not operate power tools in explosive atmospheres, such as in the presence of flammable liquids, gases or dust.** Power tools create sparks which may ignite the dust or fumes.

**Keep children and bystanders away while operating a power tool.** Distractions can cause you to lose control.

#### Electrical safety

**Power tool plugs must match the outlet. Never modify the plug in any way. Do not use any adapter plugs with earthed (grounded) power tools.** Unmodified plugs and matching outlets will reduce risk of electric shock.

**Avoid body contact with earthed or grounded surfaces such as pipes, radiators, ranges and refrigerators.** There is an increased risk of electric shock if your body is earthed or grounded.

**Do not expose power tools to rain or wet conditions.** Water entering a power tool will increase the risk of electric shock.

**Do not abuse the cord. Never use the cord for carrying, pulling or unplugging the power tool. Keep cord away from heat, oil, sharp edges or moving parts.** Damaged or entangled cords increase the risk of electric shock.

**When operating a power tool outdoors, use an extension cord suitable for outdoor use.** Use of a cord suitable for outdoor use reduces the risk of electric shock.

**If operating a power tool in a damp location is unavoidable, use a Ground Fault Circuit Interrupter (GFCI) protected supply.** Use of an GFCI reduces the risk of electric shock.

#### Personal safety

**Stay alert, watch what you are doing and use common sense when operating a power tool. Do not use a power tool while you are tired or under the influence of drugs, alcohol or medication.** A moment of inattention while operating power tools may result in serious personal injury.

-2-

**Use personal protective equipment. Always wear eye protection.** Protective equipment such as dust mask, non-skid safety shoes, hard hat, or hearing protection used for appropriate conditions will reduce personal injuries.

**Prevent unintentional starting. Ensure the switch is in the off-position before connecting to power source and / or battery pack, picking up or carrying the tool.** Carrying power tools with your finger on the switch or energizing power tools that have the switch on invites accidents.

**Remove any adjusting key or wrench before turning the power tool on.** A wrench or a key left attached to a rotating part of the power tool may result in personal injury.

**Do not overreach. Keep proper footing and balance at all times.** This enables better control of the power tool in unexpected situations.

**Dress properly. Do not wear loose clothing or jewelry. Keep your hair, clothing and gloves away from moving parts.** Loose clothes, jewelry or long hair can be caught in moving parts.

**If devices are provided for the connection of dust extraction and collection facilities, ensure these are connected and properly used.** Use of dust collection can reduce dust-related hazards.

#### Power tool use and care

**Do not force the power tool. Use the correct power tool for your application.** The correct power tool will do the job better and safer at the rate for which it was designed.

**Do not use the power tool if the switch does**

**not turn it on and off.** Any power tool that cannot be controlled with the switch is dangerous and must be repaired.

**Disconnect the plug from the power source and/or the battery pack from the power tool before making any adjustments, changing accessories, or storing power tools.** Such preventive safety measures reduce the risk of starting the power tool accidentally.

**Store idle power tools out of the reach of children and do not allow persons unfamiliar with the power tool or these instructions to operate the power tool or these instructions are dangerous in the hands of untrained users.**

**Maintain power tools. Check for misalignment or binding of moving parts, breakage of parts and any other condition that may affect the power tool's operation. If damaged, have the power tool repaired before use.** Many accidents are caused by poorly maintained power tools.

**Keep cutting tools sharp and clean.** Properly maintained cutting tools with sharp cutting edges are less likely to bind and are easier to control.

**Use the power tool, accessories and tool bits etc. in accordance with these instructions, taking into account the working conditions and the work to be performed.** Use of the power tool for operations different from those intended could result in a hazardous situation.

#### Service

**Have your power tool serviced by a qualified repair person using only identical replacement parts.** This will ensure the safety of the power tool is maintained.

### Rotary Hammer Safety Rules

**Wear ear protectors.** Exposure to noise can cause hearing loss.

**Use auxiliary handle(s), if supplied with the tool.** Loss of control can cause personal injury.

**Hold power tools by insulated gripping surfaces, when performing an operation where the cutting tool may contact hidden wiring or its own cord.** Cutting accessory contacting a "live" wire may make exposed metal parts of the power tool "live" and could give the operator an electric shock.

**Use clamps or another practical way to secure and support the workpiece to a stable platform.** Holding the work by hand

or against your body leaves it unstable and may lead to loss of control.

**Do not drill, fasten or break into existing walls or other blind areas where electrical wiring may exist.** If this situation is unavoidable, disconnect all fuses or circuit breakers feeding this worksite.

**Use a metal detector to determine if there are gas or water pipes hidden in the work area or call the local utility company for assistance before beginning the operation.** Striking or cutting into a gas line will result in explosion. Water entering an electrical device may cause electrocution.

**Always use the side handle for maximum control over torque reaction or kick-back. Never attempt to operate this tool with one hand.** The slip clutch engages if you firmly control the tool during a torque reaction or kickback.

**Always wear safety goggles or eye protection when using this tool. Use a dust mask or respirator for applications that generate dust.** Safety goggles or eye protection will help deflect fragments of the material that may be thrown toward your face and eyes. Dust generated or gases released from the material you are cutting (i.e. asbestos insulated pipes, radon) may cause respiratory difficulties.

**Use thick cushioned gloves and limit the exposure time by taking frequent rest periods.** Vibration caused by hammer-drill action may be harmful to your hands and arms.

**Position the cord clear of rotating bit. Do not wrap the cord around your arm or wrist.** If cord becomes entangled with the spinning bit it could entrap you causing serious personal injury.

**Position yourself to avoid being caught between the tool or side handle and walls or posts.** Should the bit become bound or jammed in the work, the reaction torque of the tool could crush your hand or leg.

**Do not strike the bit with a hand held hammer or sledgehammer when attempting to dislodge a bound or jammed bit.** Fragments of metal from the bit could dislodge and strike you or bystanders.

**Never place the tool down until the bit or accessory has come to a complete stop.**

**Do not use dull or damaged bits and accessories.** Dull or damaged bits have a greater tendency to bind in the workpiece.

**When removing the bit from the tool avoid contact with skin and use proper protective gloves when grasping the bit or accessory.** Accessories may be hot after prolonged use.

**Do not run the tool while carrying it at your side.** A spinning bit could become entangled with clothing and injury may result.

### Additional Safety Warnings

GFCI and personal protection devices like electrician's rubber gloves and footwear will further enhance your personal safety.

**Do not use AC only rated tools with a DC power supply.** While the tool may appear to work, the electrical components of the AC rated tool are likely to fail and create a hazard to the operator.

**Keep handles dry, clean and free from oil and grease.** Slippery hands cannot safely control the power tool.

**Develop a periodic maintenance schedule for your tool. When cleaning a tool be careful not to disassemble any portion of the tool since internal wires may be misplaced or pinched or safety guard return springs may be improperly mounted.** Certain cleaning agents such as gasoline, carbon tetrachloride, ammonia, etc. may damage plastic parts.

Risk of injury to user. The power cord must be serviced by a Bosch Factory Service Center or Authorized Bosch Service Station.

**WARNING** Some dust created by power sanding, sawing, grinding, drilling, and other construction activities contains chemicals known to cause cancer, birth defects or other reproductive harm. Some examples of these chemicals are:

- Lead from lead-based paints,
- Crystalline silica from bricks and cement and other masonry products, and
- Arsenic and chromium from chemically-treated lumber.

Your risk from these exposures varies, depending on how often you do this type of work. To reduce your exposure to these chemicals: work in a well ventilated area, and work with approved safety equipment, such as those dust masks that are specially designed to filter out microscopic particles.

### Symbols

**IMPORTANT:** Some of the following symbols may be used on your tool. Please study them and learn their meaning. Proper interpretation of these symbols will allow you to operate the tool better and safer.

Symbol	Designation / Explanation
V	Volts (voltage)
A	Amperes (current)
Hz	Hertz (frequency, cycles per second)
W	Watt (power)
kg	Kilograms (weight)
min	Minutes (time)
s	Seconds (time)
∅	Diameter (size of drill bits, grinding wheels, etc.)
$n_0$	No load speed (rotational speed at no load)
$n$	Rated speed (maximum attainable speed)
.../min	Revolutions or reciprocation per minute (revolutions, strokes, surface speed, orbits etc. per minute)
0	Off position (zero speed, zero torque...)
1, 2, 3, ... I, II, III,	Selector settings (speed, torque or position settings. Higher number means greater speed)
0 ▲	Infinitely variable selector with off (speed is increasing from 0 setting)
→	Arrow (action in the direction of arrow)
~	Alternating current (type or a characteristic of current)
—	Direct current (type or a characteristic of current)
⌋	Alternating or direct current (type or a characteristic of current)
□	Class II construction (designates double insulated construction tools)
⊕	Earthing terminal (grounding terminal)

### Symbols (continued)

**IMPORTANT:** Some of the following symbols may be used on your tool. Please study them and learn their meaning. Proper interpretation of these symbols will allow you to operate the tool better and safer.

Symbol	Designation / Explanation
	Alerts user to read manual
	Alerts user to wear eye protection
	This symbol designates that this tool is listed by Underwriters Laboratories.
	This symbol designates that this tool is listed by Underwriters Laboratories, to United States and Canadian Standards.
	This symbol designates that this tool is listed by the Canadian Standards Association.
	This symbol designates that this tool is listed by the Canadian Standards Association, to United States and Canadian Standards.
	This symbol designates that this tool is listed by the Intertek Testing Services, to United States and Canadian Standards.
	This symbol designates that this tool complies to NOM Mexican Standards.

**Conforms to**  
UL Standard 60745-1  
UL Standard 60745-2-6

**Certified to**  
CAN/CSA Standard C22.2 No. 60745-1-07  
CAN/CSA Standard C22.2 No. 60745-2-6-04

### Functional Description and Specifications

**⚠ WARNING** Disconnect the plug from the power source before making any assembly, adjustments or changing accessories. Such preventive safety measures reduce the risk of starting the tool accidentally.

#### Rotary Hammer

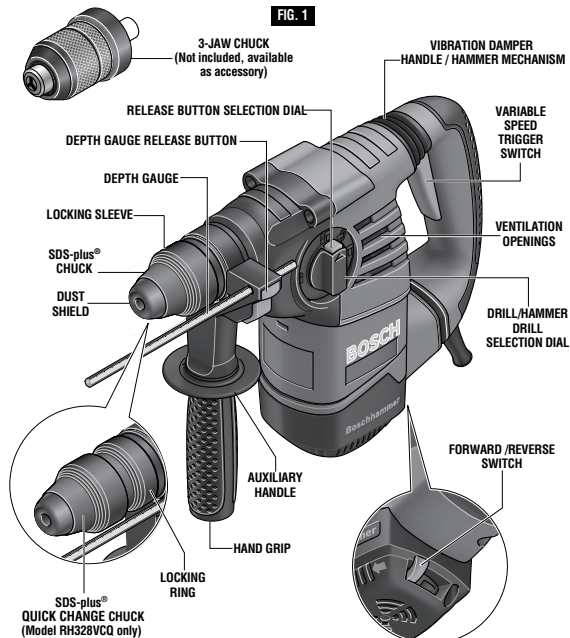

Model number RH328VC & RH328VCQ  
Shank style SDS-plus®  
Maximum Capacities:  
Carbide tipped bits 1-1/8"  
Thin wall core bits 3-1/4"

**NOTE:** For tool specifications refer to the nameplate on your tool.

### Assembly

**⚠ WARNING** Disconnect the plug from the power source before making any assembly, adjustments or changing accessories. Such preventive safety measures reduce the risk of starting the tool accidentally.

**INSTALLING SDS-plus® ACCESSORIES**  
Clean the insert shank end of the accessory to remove any debris, then lightly grease with a light oil or lubricant.

Insert accessory into the chuck through the dust shield, while twisting and pushing inward until it locks automatically into place. Pull outward on the accessory to be certain it is locked into the chuck (Fig. 2).

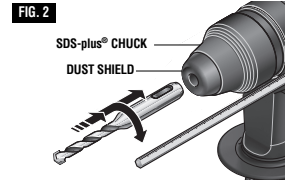

**NOTE:** The high efficiency available from the rotary hammers can only be obtained if sharp and undamaged accessories are used. The "cost" to maintain sharp and undamaged accessories is more than offset by the "time saved" in operating the tool with sharp accessories.

**REMOVING SDS-plus® ACCESSORIES**  
**⚠ WARNING** Accessories may be hot after use. Avoid contact with skin and use proper protective gloves or cloth to remove.

To remove an accessory, pull locking sleeve backward and pull bit forward. All accessories should be wiped clean after removing (Fig. 3).

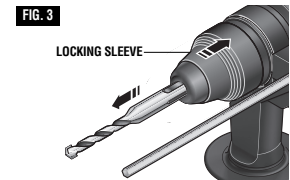

**Note:** when replacing original SDS-plus quick change chuck, always make sure the replacement chuck has the proper number of identification grooves.

**REMOVING THE SDS-plus® QUICK CHANGE CHUCK (Model RH328VCQ only)**  
Grasp the locking ring of the SDS-plus quick change chuck and pull forcefully in direction of arrow A while pulling chuck in direction of arrow B and remove from tool (Fig. 4).

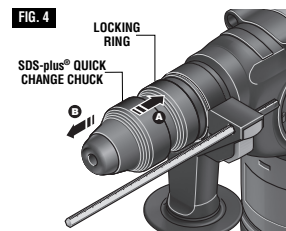

**ATTACHING SDS-plus® QUICK CHANGE CHUCK (Model RH328VCQ only)**

Before attaching the chuck apply a light coat of grease to end of the shank.

Grasp the SDS-plus chuck firmly with your hand and push it onto the tool with a twisting motion until you hear it lock into place (Fig. 5).

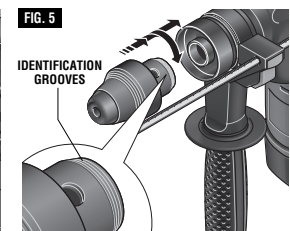

**WARNING** Do not carry the tool by the chuck. Tool may unexpectedly fall if the chuck is not fully engaged.

The SDS-plus chuck can easily be exchanged for the 3-jaw chuck.

Hammer drilling and chiseling are only possible when using the SDS-plus chuck with SDS-plus shank accessories.

The 3-jaw chuck converts your tool for use with a variety of straight shank bits for drilling and driving.

**REMOVING THE SDS-plus® CHUCK (Model RH328VCQ only)**

Grasp the locking ring of the SDS-plus chuck and pull forcefully in direction of arrow and remove from tool (Fig. 4).

**ATTACHING THE 3-JAW CHUCK (Model RH328VCQ only)**

(Not included, available as accessory)

Grasp the 3-jaw chuck firmly with your hand and push it onto the tool with a twisting motion until you hear it lock into place (Fig. 6).

Pull outward on the chuck to be certain it is locked into the tool.

FIG. 6

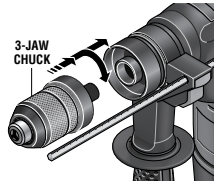

**INSTALLING ACCESSORIES**

**3-JAW CHUCK**

(Model RH328VCQ only)

(Not included, available as accessory)

Hold chuck collar with one hand and rotate chuck sleeve in direction of arrow with the other hand until the jaws are open (Fig. 7).

For small bits, open jaws enough to insert the bit up to the flutes. For large bits, insert the bit as far as it will go.

Insert bit, hold the chuck collar with one hand and rotate chuck sleeve in direction of arrow with the other hand until it latches. Then clamp the accessory by continuing to turn the chuck

sleeve forcefully in direction of arrow until you hear a ratcheting sound (Fig. 8).

**Note:** If after opening the chuck completely you hear a ratcheting sound when closing, simply open it a quarter turn and then resume closing the chuck. The ratcheting sound will stop.

**REMOVING ACCESSORIES**

**3-JAW CHUCK**

To remove an accessory, hold chuck collar with one hand and rotate chuck sleeve in direction of arrow with the other hand until the accessory can be removed (Fig. 8).

FIG. 7

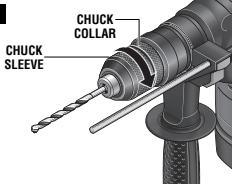
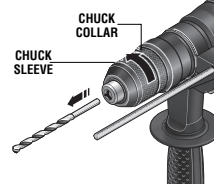

FIG. 8



**Operating Instructions**

**VARIABLE SPEED CONTROLLED TRIGGER SWITCH**

Your tool is equipped with a variable speed trigger switch. The tool can be turned "ON" or "OFF" by squeezing or releasing the trigger.

The speed can be adjusted from the minimum to maximum nameplate RPM by the pressure you apply to the trigger. Apply more pressure to increase the speed and release pressure to decrease speed (Fig. 1).

**FORWARD/REVERSE SWITCH**

The reversing switch is used to reverse rotation of the bit (Fig. 1).

**CAUTION** The reversing switch should only be activated when the motor is "OFF" and when bit is at a complete standstill.

Setting depth: After the auxiliary handle is installed, make sure the accessory has been fully inserted into the tool holder before setting the depth gauge (Fig. 10).

To adjust depth, push the depth gauge release button, slide the depth gauge to desired depth and release pressure on button to lock the depth gauge in place.

FIG. 9

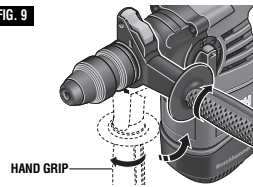
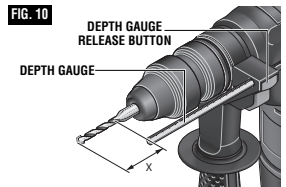

FIG. 10



To use tool in "Forward" rotation move switch toward the arrow that depicts forward.

"Reverse" the rotation of the bit move the switch toward arrow that depicts reverse.

**SELECTOR DIAL**

The selector dial allows the tool to be set for various drilling/hammer drilling and chipping applications. Depress release button and turn selector dial right or left depending on the below applications (Fig. 11).

When using demolition or chipping bits such as bull points, chisels, spades, gouges, etc. the "Hammer Only" mode must be selected.

**CAUTION** Do not operate the selection dial until the tool comes to a complete stop. Shifting during rotation of the chuck can cause damage to the tool.

<p><b>Drilling only:</b> used for drilling wood, steel, etc.</p>	<p><b>Drilling/hammering:</b> used for drilling concrete</p>	<p><b>Vario-lock</b> allows for 12 desired positions of "hammer"</p>	<p><b>Hammering only:</b> used for light chipping work</p>
--	--	--	--

FIG. 11

**"VARIO-LOCK"- SELECTOR DIAL**

The vario-lock can be set in any one of twelve positions (30° increments). Choose a position which is best suited for your operation. The Vario-Lock position is intended for use with chipping bits such as bull points, spades, gouges, etc.

Rotate the selector dial, to the "vario-lock" setting. Next, rotate the locking sleeve, along with the accessory, to the desired position. Then turn the selector dial to the "hammer only" setting and slightly turn the locking sleeve to have it automatically lock into a definite position.

**VIBRATION DAMPER HANDLE / HAMMER MECHANISM**

The integrated vibration damper in the main handle and hammer mechanism reduces vibrations (Fig. 1).

**SLIP CLUTCH**

The tool has an internal pre-set slip clutch. The output spindle will stop rotating if the accessory binds and overloads the tool.

**TOOL TIPS**

Following a few simple tips will reduce wear on the tool and the chance of injury to the operator.

The high efficiency available from the BOSCH Rotary Hammer can only be obtained if sharp and undamaged drilling tools are used. Note that the costs for maintaining sharp drilling tools are more than offset by the time lost in operating dull drilling tools.

All grease packed hammers require a short time to warm up. Depending on the temperature, this time will vary from approximately 15 seconds (90° F) to 2 minutes (32° F). The tool will exert its full power and hammering action after the heat from impact hammering has spread, softening the grease.

**CARBIDE TIPPED BITS**

Used for drilling stone, concrete, cement, brick, cinder block and other unusually hard non-metals. The Rotary Hammer is designed for "SDS" Carbide Tipped Bits up to 3/4 inch diameter.

**3 JAW CHUCK**

The 3 Jaw Chuck can convert your tool for use with straight shank bits.

You will extend the life of your bits and do neater work if you always put the bit in contact with the workpiece BEFORE pulling the trigger. During operation, hold the drill firmly and exert moderate, steady pressure. Too much pressure at low speed will stall the hammer. Too little pressure will keep the bit from cutting and cause excess friction by sliding over the surface. This can be damaging to the drill and bit.

Shanks of all drill bits should be wiped clean prior to using and immediately after removing.

**RECALL THESE INSTRUCTIONS FOR SAFE OPERATION:**

1. Some materials require slow drilling speeds; whereas, others require higher speed to produce the best results.
2. All work must be supported or secured before drilling and steady, even pressure applied in line with the drill bit.
3. As the drill bit cuts through the opposite side, reduce the pressure and continue running the drill as the bit is withdrawn.

Materials such as glass, porcelain, ceramics, tiles, plastics, etc., should be drilled at low speeds with specially designed drill bits and lubricants.

**DRILLING WOOD OR PLASTIC**

If backing block is not used, ease up on the pressure just before the bit breaks through the wood to avoid splintering. Complete the hole from the opposite side immediately after the point breaks through. If bit binds, reverse the drilling operation to help remove the bit from the work.

**DRILLING METAL**

Make a center punch in the material for easier starting. Use enough pressure to keep the bit cutting. If the bit is allowed to merely spin in the hole, it will become dull within a short time. When drilling a larger hole, it is faster and easier on your power pack to first make a smaller hole and enlarge it to the required size. Lubricate the tip of the bit occasionally with CUTTING OIL for easier metal drilling. If bit binds, reverse the drilling to help remove the bit from the work.

**DRILLING MASONRY**

Use carbide-tipped SDS-plus® bit for cinder block, mortar, common brick, soft stone and other materials. The amount of pressure to be used is dependent upon the type of material being drilled. Soft materials require less pressure while the hard materials need more pressure to prevent the drill bit from spinning.

**Dust Extraction**

For selection of dust collection systems and operating instructions, see the Operating / Safety Instructions for "Dust Extraction"

Attachments for Hammers and Hammer Drills included with your tool or with the dust extraction attachment.

**Maintenance**

**Service**

**WARNING** Preventive maintenance performed by unauthorized personnel may result in misplacement of internal wires and components which could cause serious hazard. We recommend that all tool service be performed by a Bosch Factory Service Center or Authorized Bosch Service Station.

**TOOL LUBRICATION**

Your Bosch tool has been properly lubricated and is ready to use. It is recommended that tools with gears be regreased with a special gear lubricant at every brush change.

**CARBON BRUSHES**

The brushes and commutator in your tool have been engineered for many hours of dependable service. To maintain peak efficiency of the motor, we recommend every two to six months the brushes be examined. Only genuine Bosch replacement brushes specially designed for your tool should be used.

**BEARINGS**

Every second brush change, the bearings

should be replaced at Bosch Factory Service Center or Authorized Bosch Service Station. Bearings which become noisy (due to heavy load or very abrasive material cutting) should be replaced at once to avoid overheating or motor failure.

**Cleaning**

**WARNING** To avoid accidents always disconnect the tool from the power supply before cleaning or performing any maintenance. The tool may be cleaned most effectively with compressed dry air. Always wear safety goggles when cleaning tools with compressed air.

Ventilation openings and switch levers must be kept clean and free of foreign matter. Do not attempt to clean by inserting pointed objects through openings.

**CAUTION** Certain cleaning agents and solvents damage plastic parts. Some of these are: gasoline, carbon tetrachloride, chlorinated cleaning solvents, ammonia and household detergents that contain ammonia.

**Extension Cords**

**WARNING** If an extension cord is necessary, a cord with adequate size conductors that is capable of carrying the current necessary for your tool must be used. This will prevent excessive voltage drop, loss of power or overheating. Grounded tools must use 3-wire extension cords that have 3-prong plugs and receptacles.

**NOTE:** The smaller the gauge number, the higher the cord capacity.

**RECOMMENDED SIZES OF EXTENSION CORDS 120 VOLT ALTERNATING CURRENT TOOLS**

Tool's Ampere Rating	Cord Size in A.W.G.				Wire Sizes in mm <sup>2</sup>			
	25	50	100	150	15	30	60	120
3-6	18	16	16	14	0.75	0.75	1.5	2.5
6-8	18	16	14	12	0.75	1.0	2.5	4.0
8-10	18	16	14	12	0.75	1.0	2.5	4.0
10-12	16	16	14	12	1.0	2.5	4.0	-
12-16	14	12	-	-	-	-	-	-

**Accessories**

- \* Auxiliary Handle
- \* Carrying case

- (\* = standard equipment)
- (\*\* = optional accessories)